

LOC	DIST	REVISIONS			
		REV	DATE	BY	CHKD
AD	14	0	1/7/97	RB	MB
		A	2/3/97	RB	MB
		B	8/14/97	RB	MB
		C	11/12/97	RB	MB
		D	4/20/98	RB	DD
		E	8/4/98	RB	DD
		F	01/17/99	MM	EL
		G	01/20/99	MM	DD
		H	05/17/99	MM	EL

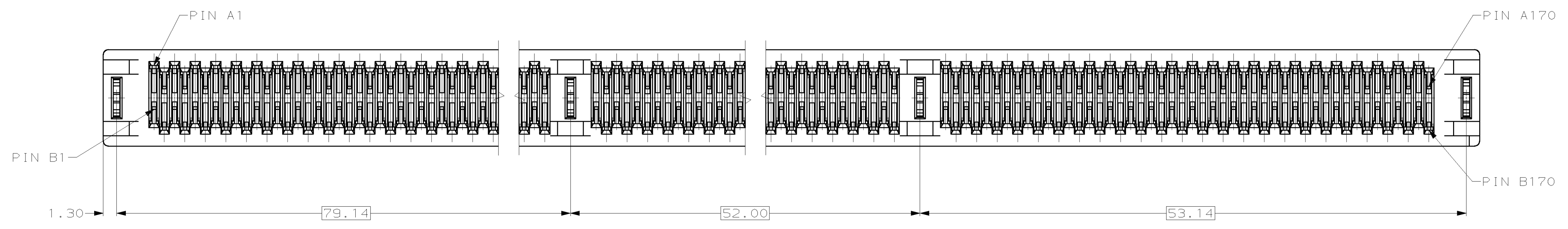
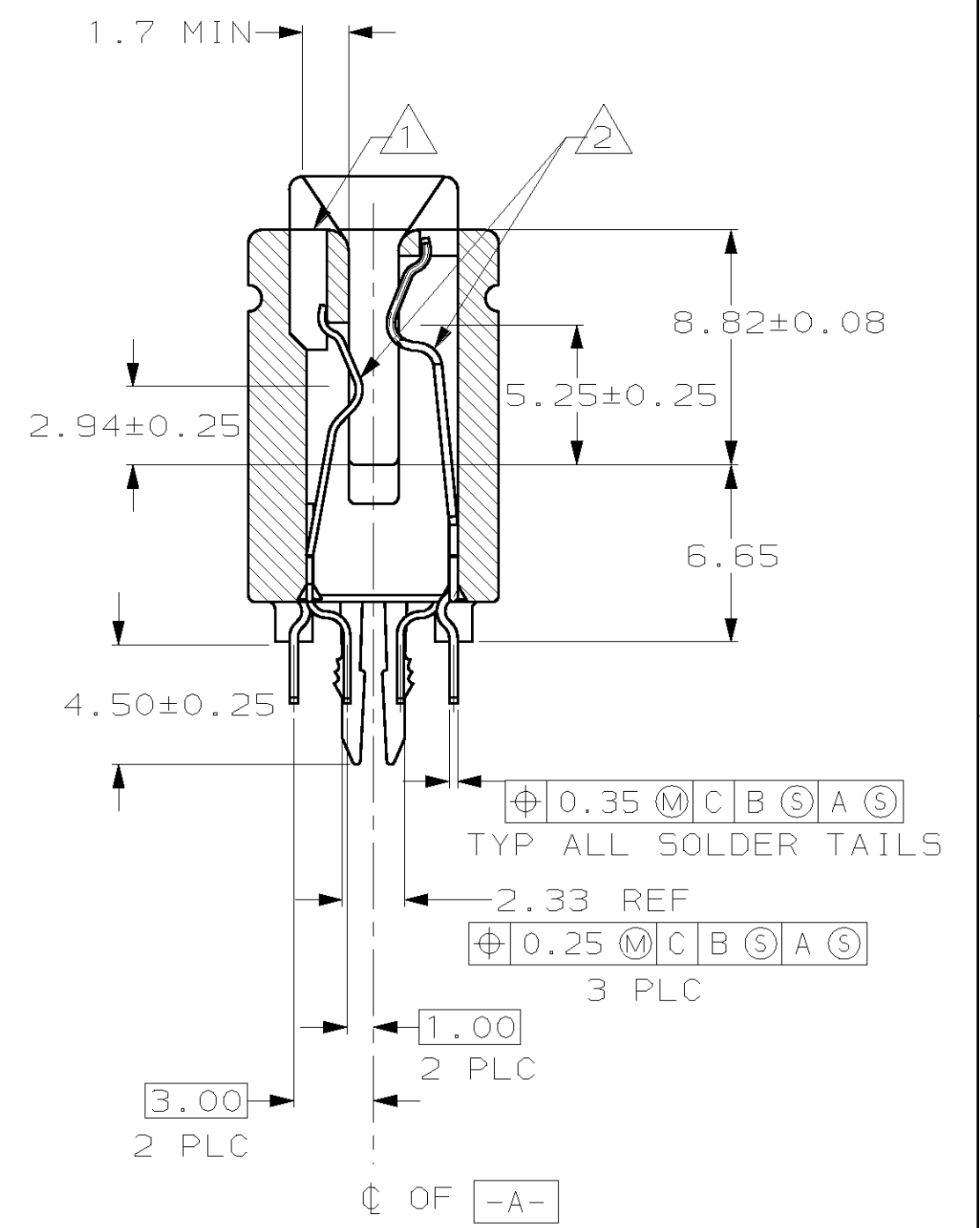
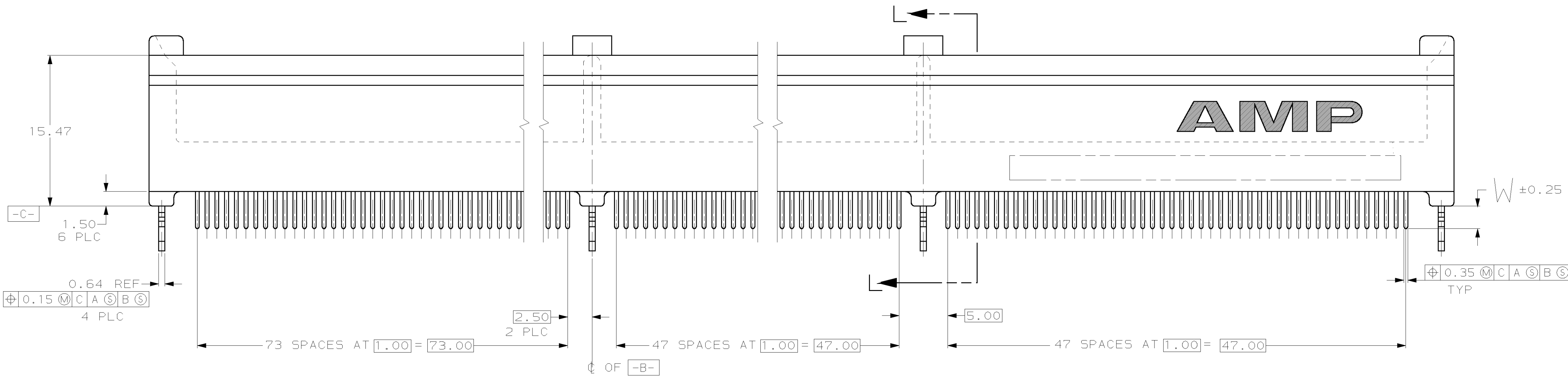
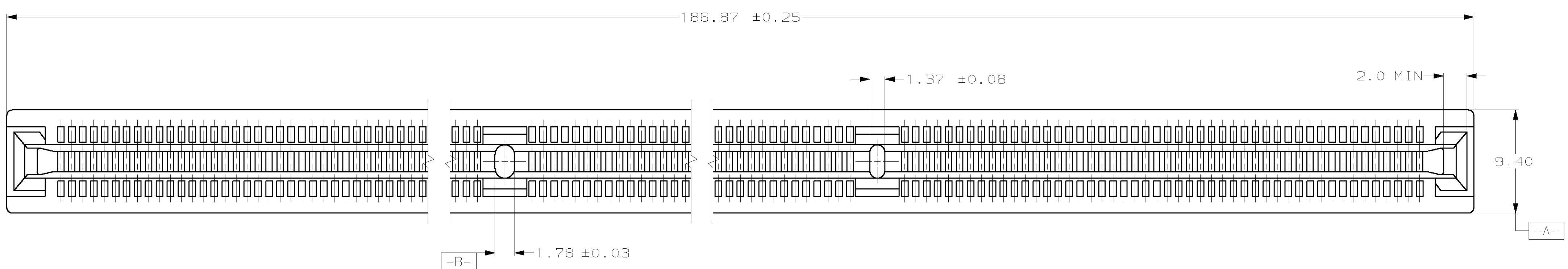

- 1 MATERIAL: HOUSING, THERMOPLASTIC, COLOR: BROWN.
CONTACTS, PHOSPHOR BRONZE.
HOLD-DOWNS, BRASS.
- 2 FINISH: CONTACTS, 1.27 MIN. MICROMETERS NICKEL ALL OVER,
0.38 MIN. MICROMETERS GOLD OVER NICKEL IN CONTACT AREA,
2.54 MIN MICROMETERS TIN-LEAD OVER NICKEL ON SOLDER TAILS.
- 3 FINISH: CONTACTS, 1.27 MIN. MICROMETERS NICKEL ALL OVER,
0.0254-0.0762 MICROMETERS GOLD OVER NICKEL IN CONTACT AREA.
2.54 MIN. MICROMETERS TIN-LEAD OVER NICKEL ON SOLDER TAILS.

3	3.18	145275-6
2	2.54	145275-5
3	3.18	145275-3
2	2.54	145275-2
2	2.16	145275-1
PLATING		W
		PART NO

THIS DRAWING IS A CONTROLLED DOCUMENT.

DIMENSIONS:	TOLERANCES UNLESS OTHERWISE SPECIFIED.	DWN	R. BROWN	1/7/97
mm	0 PLC ±	CHK	M. BOWERS	1/7/97
	1 PLC ±0.13	APVD	D. SARVER	1/7/97
	2 PLC ±0.13	PRODUCT SPEC		
	3 PLC ±0.013	APPLICATION SPEC		
	4 PLC ±	WEIGHT		
	ANGLES ±	CUSTOMER DRAWING		

AMP Incorporated
Harrisburg, PA 17105-3608

ASSEMBLY, 340 POSITION
1mm, CARD EDGE CONNECTOR

A1 00779 C-145275

SCALE 4:1 SHEET 1 OF 2 REV H

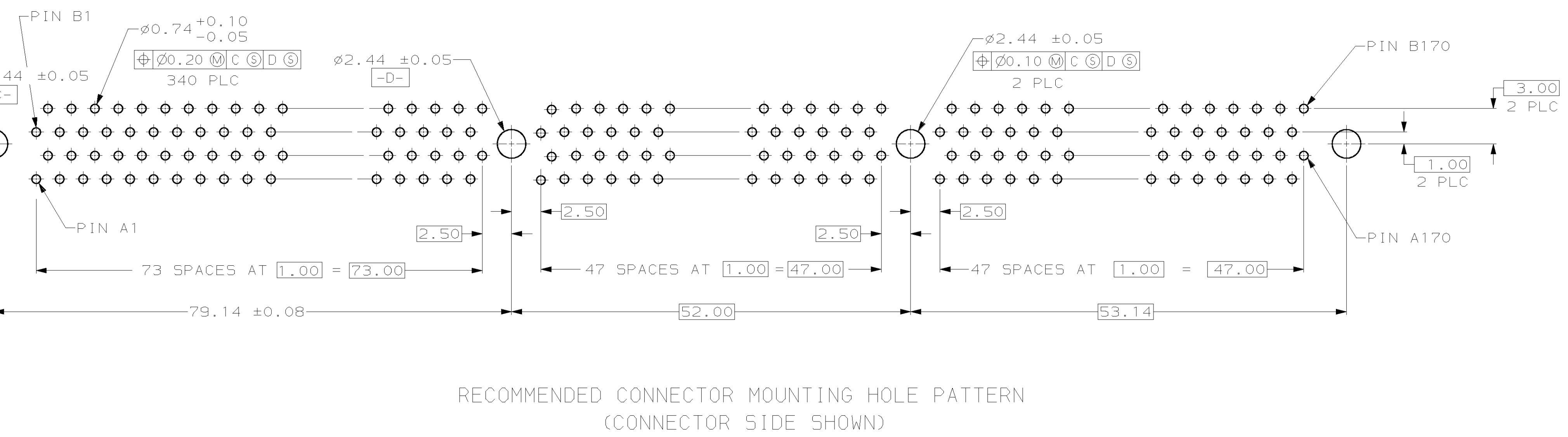
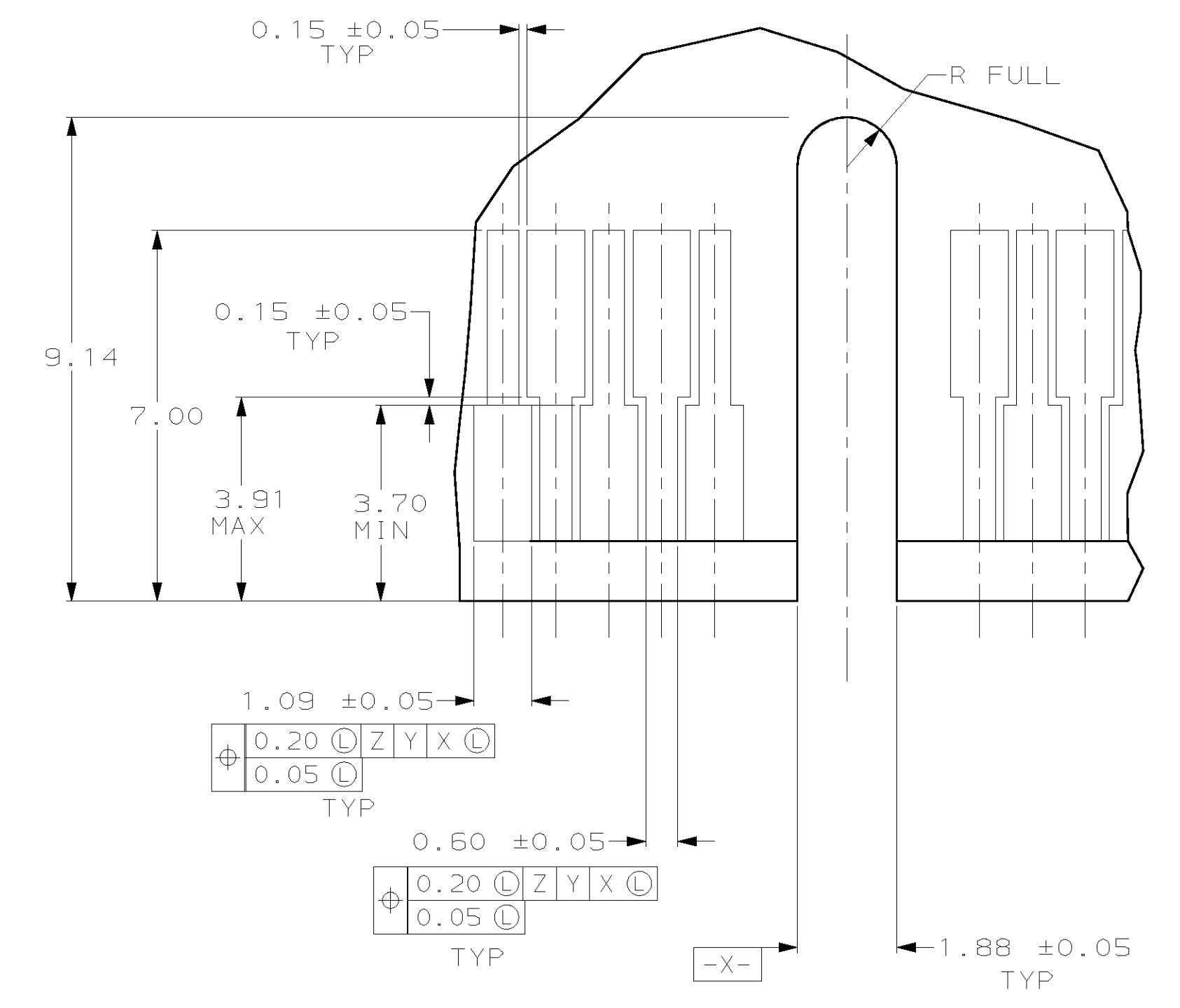
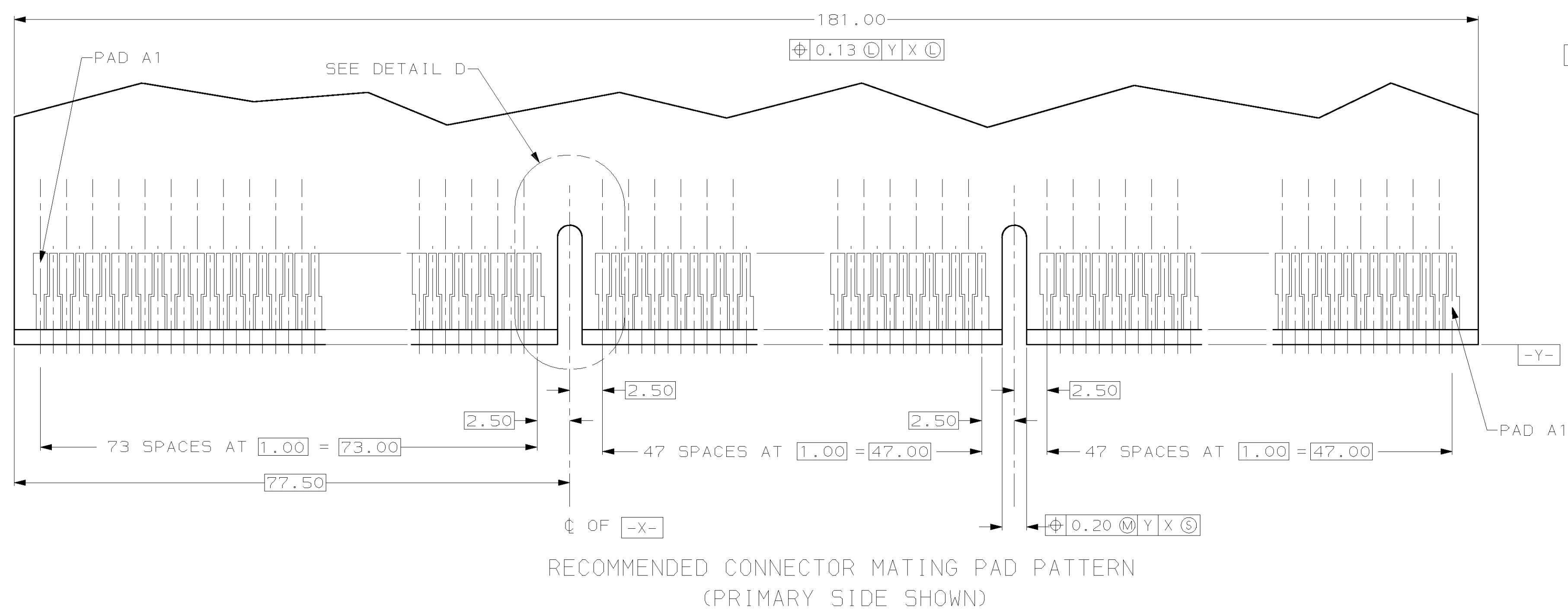
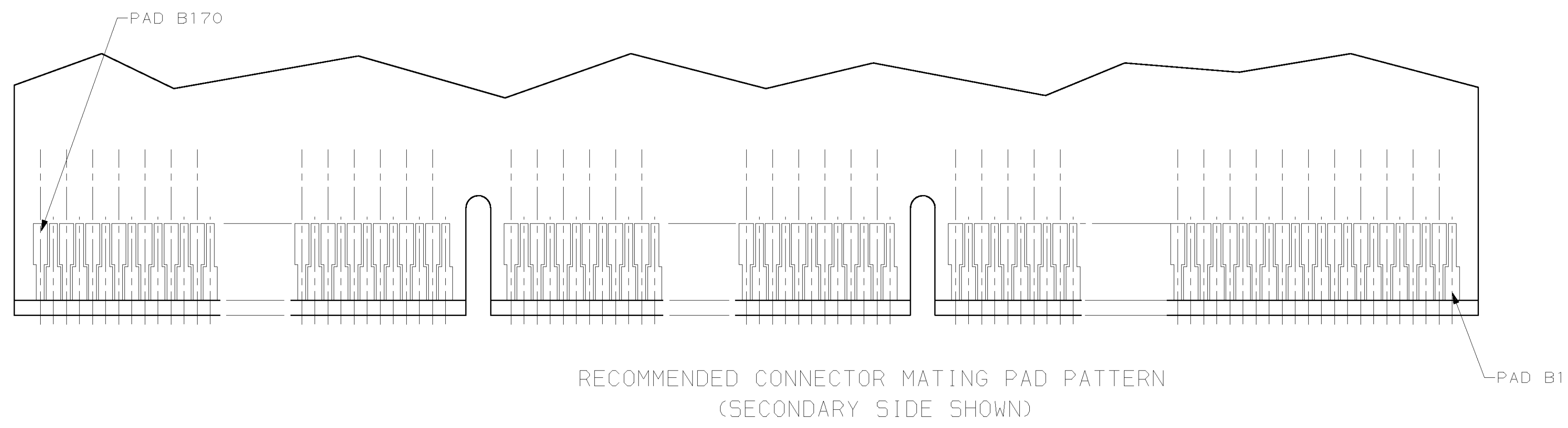

THIS DRAWING IS A CONTROLLED DOCUMENT.		DWN R BROWN 1/7/97	AMP Incorporated Harrisburg, PA 17105-3608
DIMENSIONS mm	TOLERANCES UNLESS OTHERWISE SPECIFIED.	CHK M BOWERS 1/7/97	NAME D SARVER 1/7/97
0 PLC ±	1 PLC ±	PRODUCT SPEC	ASSEMBLY, 340 POSITION 1mm CARD EDGE CONNECTOR
2 PLC ±0.13	3 PLC ±	APPLICATION SPEC	SIZE A1 00779
4 PLC ±	ANGLES ±	WEIGHT	CAGE CODE C-145275
MATERIAL	FINISH	CUSTOMER DRAWING	DRAWING NO SCALE 4:1 SHEET 22 REV H